

# **Special Olympics Northern California and Nevada**

## **Golf**



### **2008 Guidelines and Rules**

# **TABLE OF CONTENTS**

**SPECIAL OLYMPICS MISSION**

**SONC / SONV PLAYS BY THE RULES**

**SPECIAL OLYMPICS NORTHERN CALIFORNIA AND NEVADA COACHES CODE OF CONDUCT**

**SPECIAL OLYMPICS NORTHERN CALIFORNIA AND NEVADA ATHLETES' CODE OF CONDUCT**

**SONC / SONV GOLF RULES AND REGULATIONS**

Section A - General Rules

Section B - Official Events

Section C - Divisioning

Section D - Uniforms

Section E - Equipment

Section F - Officials and Their Duties

Section G - Coaches and Their Responsibilities

Section H - Rules of Competition

1. Level 2 - Alternate Shot Team Play Competition
2. Level 4 - Individual Stroke Play Competition (9 Hole)
2. Level 5 – Individual Stroke Play Competition (18 Hole)

Section I - Golf Course Set-up

Section J - Level 1 - Individual Skills Contest

1. Rules
2. Score sheets

# **SPECIAL OLYMPICS**

## **MISSION STATEMENT**

**The mission of Special Olympics is to provide year-round sports training and athletic competition in a variety of Olympic type sports for children and adults with mental retardation, giving them continuing opportunities to develop physical fitness, demonstrate courage, experience joy and participate in a sharing of gifts, skills and friendship with their families, other Special Olympics Athletes and the community.**

## ***Training For Life***

### **SONC / SONV PLAYS BY THE RULES.....**

**All Special Olympics competitions will be conducted in accordance with the Official Special Olympics Sports Rules and the National Governing Body of rules for each sport offered in our program. These rules are designed to protect the Athletes, provide equitable conditions of competition and promote uniformity so that no competitor shall obtain an unfair advantage over another.**

**The International Olympics Committee (IOC), has granted its official recognition to Special Olympics International, Inc. and its accredited programs.**

# Special Olympics Northern California and Nevada

## COACHES' CODE OF CONDUCT

Special Olympics Northern California and Nevada (SONC/SONV) volunteer coaches are models whose behavior should serve as a positive example for their athletes. Their behavior should reflect a concern that the fairest and most positive competitive experience is equally available to every Special Olympics athlete in each training or competition. The coach has the unique opportunity to influence the development and personal growth of many individuals. For this reason, it is important that the coach adhere to the standards of ethical decision making and teaching.

In addition, it is the position of SONC/SONV that each volunteer coach shall agree to:

### HAVE RESPECT FOR OTHERS

- I will respect the rights, dignity and worth of athletes, other coaches and volunteers, SONC/SONV staff members, and friends and spectators in Special Olympics.
- I will treat everyone equally regardless of sex, ethnic origin, religion or ability.
- I will be a positive role model for the athletes I coach.

### ENSURE A POSITIVE EXPERIENCE

- I will ensure that for each athlete I coach, the time spent with Special Olympics is a positive experience.
- I will respect the talent, developmental stage and goals of each athlete.
- I will ensure each athlete competes in events that challenge that athlete's potential and are appropriate to that athlete's ability.
- I will be fair, considerate and honest with athletes and communicate with athletes using simple, clear language.
- I will ensure that accurate scores are provided for entry of an athlete into any event.
- I will instruct each athlete to perform to the best of the athlete's ability at all preliminaries/heats and finals in accordance with the Official Special Olympics Sports Rules.

### ACT PROFESSIONALLY AND TAKE RESPONSIBILITY FOR HIS/HER ACTIONS

- My language, manner, punctuality, preparation and presentation will demonstrate high standards.
- I will display control, respect, dignity and professionalism to all involved in Special Olympics, including to the athletes, other coaches and volunteers, opponents, officials, administrators, SONC/SONV staff members, parents, spectators and the media.
- I will encourage athletes to demonstrate the same qualities.
- I will not drink alcohol, smoke or take illegal drugs while representing Special Olympics at training sessions or during competitions.
- I will not engage in any form of personal abuse towards athletes, other coaches and volunteers, SONC/SONV staff members, or friends and spectators in Special Olympics, including verbal, physical or emotional abuse.
- I will be alert to any form of abuse from other sources directed toward athletes or others in my care.

### PROVIDE QUALITY SERVICE TO THE ATHLETES

- I will seek continued improvement through performance evaluation and ongoing coach education.
- I will be knowledgeable about the Sports Rules and skills of the sport(s) I coach.
- I will provide a planned training program.
- I will keep copies of the registration, training, and competition records for each athlete I coach.

- I will follow the Special Olympics and National Governing Body rules for my sport(s) coached, as well as all SONC/SONV policies and procedures as amended.

**ENSURE THE HEALTH AND SAFETY OF THE ATHLETES**

- I will ensure that the equipment and facilities for my sport(s) coached are safe to use.
- I will ensure that the equipment, rules, training and the environment are appropriate for the age and ability of the athletes.
- I will review each athlete’s registration form and be aware of any limitations on that athlete’s participation noted on that form.
- I will encourage athletes to seek medical advice when needed.
- I will maintain the same interest and support towards sick and injured athletes.
- I will allow further participation in training and competition only when appropriate.

Should the behaviors and/or abilities of any volunteer coach or other faction of a school/organization violate either the principles stated above (including the SONC/SONV policies and procedures as amended) or the philosophy of the Special Olympics movement, then any of the following actions may be taken by SONC/SONV in its sole discretion:

1. The coach may be notified by official warning of the undesirable behavior and be requested to remedy the situation immediately in order to continue his or her participation in Special Olympics;
2. The coach may be requested to withdraw personally or with his/her team from the remainder of any Special Olympics event or tournament;
3. The coach or sponsoring school/organization may be suspended from participating in any or all Special Olympics activities or events for a specified period of time; and/or
4. The coach or sponsoring school/organization may be permanently prohibited from participating in any or all Special Olympics activities or events.

I have read and understand the foregoing SONC/SONV Coaches’ Code of Conduct, and agree to abide by its terms.

By: \_\_\_\_\_  
*(Signature of Volunteer Coach)*

Print Full Name: \_\_\_\_\_

Date: \_\_\_\_\_

# Special Olympics

## Northern California and Nevada

### ATHLETE'S CODE OF CONDUCT

Special Olympics Northern California and Nevada (SONC / SONV) is committed to the highest ideals of sport and expects all athletes to honor sports and Special Olympics. All SONC / SONV Athletes and Unified Partners agree to the following code:

#### SPORTSMANSHIP

- I will practice good sportsmanship.
- I will act in ways that bring respect to me, my coaches, my team, and Special Olympics.
- I will not use bad language.
- I will not swear or insult other persons.
- I will not fight with other athletes, coaches, volunteers, or staff.

#### TRAINING AND COMPETITION

- I will train regularly.
- I will learn and follow the rules of my sport.
- I will listen to my coaches and the official and ask questions when I do not understand
- I will always try my best during training, divisioning, and competitions.
- I will not "hold back" in preliminary competition just to get into an easier finals competition division.

#### RESPONSIBILITY FOR MY ACTIONS

- I will not make inappropriate or unwanted physical, verbal, or sexual advances on others.
- I will not smoke in non-smoking areas.
- I will not drink alcohol or use illegal drugs at Special Olympics venues
- I will not take drugs for the purpose of improving my performance.
- I will obey all laws and Special Olympics rules, the International Federation and the National Federation/Governing Body rules for my sport(s).

I agree to obey this code and I understand that if I do not obey this Code of Conduct, I will be subject to a range of consequences by SONC / SONV program up to and including not being allowed to participate.

# SONC / SONV GOLF RULES AND REGULATIONS

The Official Special Olympics Rules shall govern all Special Olympics Golf competitions. As an International sports program, Special Olympics has created these rules based upon The Rules of Golf as approved by the Royal and Ancient Golf Club of St. Andrews (R&A) and the United States Golf Association. These rules shall govern all competition except when in conflict with the Official Special Olympics Sports Rules. In such cases, the Official Special Olympics Sports Rules shall apply.

## SECTION A - GENERAL RULES

1. EACH SPECIAL OLYMPICS ATHLETE IS REQUIRED TO HAVE A MEDICAL FILLED OUT BY A CERTIFIED PHYSICIAN IN ORDER TO PARTICIPATE. ALSO, EACH SPECIAL PARTNER MUST FILL OUT A UNIFIED SPORTS® PARTNER RELEASE FORM AND A VOLUNTEER BACKGROUND CHECK FORM IN ORDER TO PARTICIPATE. THIS IS IN ACCORDANCE WITH SPECIAL OLYMPICS GENERAL RULES.
2. EACH ATHLETE AND ALTERNATE SHOT TEAM IS REQUIRED TO PLAY AND SUBMIT AT LEAST 54 HOLES OF GOLF PRIOR TO PARTICIPATION IN THE REGIONAL CHAMPIONSHIPS. ATHLETES MUST ATTEND REGIONAL EVENT TO ADVANCE TO PROGRAM CHAMPIONSHIP. ANY ATHLETE WHO MEETS THE GENERAL REQUIREMENTS AND HAS DEMONSTRATED SAFE HANDLING OF GOLF CLUBS CAN PARTICIPATE IN THE SKILLS COMPETITION.
3. GOLF CART USAGE: GOLF CARTS MAY BE USED AT EVENTS FOR MEDICAL REASONS AS WELL AS ANY SAFETY ISSUES I.E. EXTREME HEAT OR FATIGUE. ALSO, CARTS MAY BE USED FOR GOLF BAGS AND THE SCOREKEEPERS. ATHLETES AND PARTNERS MAY ALSO UTILIZE THE CARTS FROM GREEN TO TEE IN THE CASE OF EXTREME LONG DISTANCES BETWEEN GREEN AND TEE. (GOLF COURSE WILL DICTATE THE USAGE. FINAL DECISIONS WILL BE MADE BY THE GOLF COMMITTEE AT EACH EVENT.

## SECTION B - OFFICIAL EVENTS

1. Level 5 – Individual Stroke Play – 18 Hole  
Golfers scoring average must be less than 130.
2. Level 4 - Individual Stroke Play Competition (9 Hole)  
Golfers scoring average must be lower than 72.
3. Level 2 – 9 Hole Alternate Shot Unified play
4. Level 1 - Individual Skills Contest (ISC)

## SECTION C - DIVISIONS

1. Competitors in Golf will compete in one of five age groups:
  - a) Ages 8-11
  - b) Ages 12-15
  - c) Ages 16-21
  - d) Ages 22-29
  - e) Ages 30 and up\* Age Groups may be combined due to low numbers and equal ability.
2. All Co-ed teams will compete in the Co-ed divisions according to ability.

## SECTION D – UNIFORMS / ATTIRE

1. All male players must wear Collared Shirts. No exceptions!
2. **Female athletes may wear shirts without collars, but no t-shirts with screen printed logos.**
3. **NO JEANS** or gym shorts may be worn.
4. **Golf shoes are recommended (spike less golf shoes or appropriate sneakers). Soft-sole spikes only! No metal spikes.**

## SECTION E - EQUIPMENT

1. Each Player is responsible for providing their own equipment.  
Minimum:
  1. A set of clubs (shall include at least one wood, one iron and one putter)
  2. A golf bag
  3. Golf balls

## SECTION F - OFFICIALS AND THEIR DUTIES

1. The golf committee will determine any rule interpretation and/or protest according to R&A and the USGA.

## SECTION G - COACHES AND THEIR RESPONSIBILITIES

1. Coaches are responsible for knowing and understanding the rules of the game, not only the modified rules in this manual, but also the International Rules of the game. The National Governing Body of rules for Special Olympics Golf is The Royal and Ancient Golf Club of St. Andrews (R&A) and the United States Golf Association (USGA). To acquire your own **USGA** Rules Book, write to:

**United States Golf Association**  
**P.O. Box 708**  
**Far Hills, NJ 07931**  
**1-908-234-2300**  
**1-908-234-9687 FAX**  
**<http://www.usga.org>**

## SECTION H - RULES OF COMPETITION

### Level 5 - Individual Stroke Play Competition – 18 Hole play

- a. Purpose for this Level of Play
  1. This level is designed to meet the needs of those Special Olympics golfers who wish to play individually in a tournament where the stipulated round is eighteen-holes.
  2. The player should be capable of playing independently and is encouraged to walk during the entire 18 hole round. Carts may be allowed if there is a medical reason for not being able to walk the entire round.
  3. **Athlete must possess a scoring average of less than 130 to participate at this level.**
  4. **Athlete must score 130 or below at a regional tournament to advance to championships.**
- b. Form of Play
  1. The form of play shall be stroke play competition.
- c. Scoring
  1. If a tenth stroke is played without holing the shot, the player shall record a score of 10x and proceed to the next hole.
- d. Ties
  1. First place ties shall be decided in the following manner:
    - a) Of the players tied for first place, the player with the fewest number of 10x scores shall be declared the winner.
  2. All other ties shall remain as ties and all players should be presented with the same award.

e. Stipulated Round

1. A stipulated round shall be eighteen holes.

f. Qualifying for Individual Stroke Play Competition – 18 Hole play

1. An athlete should have competed in a Level 4 division in a regional tournament in prior years before qualifying for individual 18 hole stroke play.
2. An athlete must have played a total of 36 holes with no more than 6 10x's.
3. Holes played on a par 3 course will not count.

## Level 4 - Individual Stroke Play Competition - Nine-Hole Play

a. Purpose for this Level of Play

1. This level is designed to meet the needs of those Special Olympics golfers who wish to play individually in a tournament where the stipulated round is nine-holes.
2. The player should be capable of playing independently and is encouraged to walk during the entire nine-hole round. Carts may be allowed if there is a medical reason for not being able to walk the entire round.
3. Athletes must possess a scoring average of less than 72 in order to participate at this level.
4. Athlete must score 72 or below at a regional tournament to advance to championships.

b. Form of Play

1. The form of play shall be stroke play competition.

c. Scoring

1. If a tenth stroke is played without holing the shot, the player shall record a score of 10x and proceed to the next hole.

d. Ties

1. First place ties shall be decided in the following manner:
  - a) Of the players tied for first place, the player with the fewest number of 10x scores shall be declared the winner.
2. All other ties shall remain as ties and all players should be presented with the same award.

e. Stipulated Round

1. A stipulated round shall be nine holes.

f. Qualifying for Individual Stroke Play Competition - Nine-Hole Play

1. An athlete should have competed in a Level 2 division in a regional tournament in prior years to qualify for individual stroke play.
2. An athlete must have played a total of 36 holes with no more than 4 10x's. Scorecards must be turned in to the Special Olympics Northern California and Nevada office 10 days before the tournament.
3. Holes played on a par 3 course will not count.

## Level 2 - Alternate Shot Unified Team Play – 9 Holes

- a. Definition of a Unified Team: A team shall include one Special Olympics athlete and an athlete without mental retardation (Partner).
- b. Purpose for this Level of Play
  1. This level is designed to give the Special Olympics athlete an opportunity for transition from skill to individual play and progress under the guidance of a partner whose ability and knowledge of golf is more advanced than that of the Special Olympics Athlete. As a result, this level does not function in the traditional Unified Sports® model where teammates are expected to be of similar ability.
  2. The partner serves as a coach and mentor, so that the Special Olympics golfer becomes self sufficient on the golf course.
  3. The players should be capable of playing independently and are encouraged to walk during the entire 9 hole round. A cart may be allowed if there is a medical reason for not being able to walk the entire round.
- c. Form of Play
 

Alternate Shot Twosomes

  1. Rule 29 of the Rules of Golf (Alternate Shot).
  2. The players play alternately from the teeing grounds and then alternate strokes until the ball is holed. The Special Olympics athlete shall play from the tee on the odd numbered holes (front nine). The Special Partner shall play from the tee on the even numbered holes (front nine). Opposite if they are playing on the back nine.
  3. Only one ball is in play on a hole.
- d. Scoring
  1. Once the ball is in play on each hole, the players shall alternate turns hitting the ball until the ball is holed or until 10 strokes have been played.
  2. If a tenth stroke is played without holing the shot, the team shall record a score of 10x and proceed to the next hole.
- e. Ties
  1. First place ties shall be decided in the following manner:
    - a) Of the teams tied for first place, the team with the fewest number of 10x shall be declared the winner.
  2. All other ties shall remain as ties and both teams should be presented with the same award.
- f. Stipulated Round
  1. A stipulated round shall be 9 holes.
- g. Qualifying for Alternate Shot Team Play
  1. A Special Olympics athlete **should** have scored a total of 54 points in a supervised skills test or competition with:
    - a) 12 points in either the long or short putt OR a total of 18 points in putting
    - b) 12 points in either chipping or putting OR a total of 18 points in chipping and pitching combined
    - c) 12 points in either irons or woods OR a total of 18 points in irons and woods combined
  2. A Special Olympics athlete must have played at least 36 holes with the same special partner. This can be done in any combination of rounds as long as the total number of holes is at least 36. e.g. a combination of 9-hole rounds; 6-hole rounds and/or 3-hole rounds; etc. There can be no more than 4 10x's per 9 holes. Scorecards must be turned in to the Special Olympics Northern California and Nevada office 10 days before the tournament. Holes played on a par 3 course will not count.
  3. Both Special Olympics athletes and special partners must have displayed a knowledge of and ability to apply the rules of etiquette of golf.

## SECTION I - Golf Course Set-up

1. The golf course shall be set-up at the discretion of the tournament committee.
2. The following criteria shall be used in determining teeing ground locations and hole distances
  - a. Avoid carry of greater than 50 yards over hazards or other obstacles.
  - b. Use existing tee locations with these recommended distances for each par:
    - Par 3 - 150 yards
    - Par 4 - 350 yards
    - Par 5 - 475 yards

1. Distinct Teeing Grounds will be determined for both the men and the women. These teeing grounds may vary from tournament to tournament based on the facility.

## SECTION J - INDIVIDUAL SKILLS CONTEST

The purpose of the Individual Skills Contest is to allow athletes to train and compete in basic golf skills. The development of these key skills is necessary prior to advancing to Alternate Shot Team play. A maximum of 120 points may be scored in the Individual Skills Contest. Any athlete who meets the general requirements and has demonstrated safe handling of golf clubs can participate in the skills competition.

### a. Short Putt

1. Purpose - To measure the athlete's ability to putt focusing on the short putt.
2. Equipment
  - a) A regulation putting green with a properly marked (target) hole.
  - b) One putter for each athlete.
  - c) Five balls for each player.
  - d) A chalker may be used to mark the circle targets around the hole.
3. Description
  - a) A target hole is selected and two circles are placed around the hole. The first circle shall have a radius of 0.5m and the second shall have a radius of 1.5m from the hole.
  - b) The athlete will have five attempts from a clearly marked spot, 2m from the hole.
  - c) The short putt should be set up on a green with as flat a surface as possible.
4. Scoring
  - a) The athlete will have five attempts to putt the ball at the hole from a line 2m from the hole, scoring points according to where the ball comes to rest.
  - b) The athlete will score one point for making a stroke at, and striking the ball. (A swing and a miss count as one attempt, and the athlete receives a score of zero.)
  - c) A second point is scored if the ball stops on or within the 1.5m circle.
  - d) A third point is scored if the ball stops on or within the .5m circle.
  - e) If the ball goes in the hole, a total of four points will be awarded for that attempt.
  - f) The short putt score shall be the sum total from the five attempts.

### b. Long Putt

1. Purpose - To measure the athlete's ability to putt focusing on the long putt.
2. Equipment
  - a) One putter for each competing athlete.
  - b) A regulation putting green with a properly marked (target) hole.
  - c) Five balls for each hole being used.
  - d) A chalker may be used to put target circles around the hole.
3. Description
  - a) A target hole is selected and two circles are placed around the hole. The first circle shall have a radius of 0.5m and the second shall have a radius of 1.5m from the hole.
  - b) The athlete will have five attempts from a marked spot, 8m from the hole.
  - c) The long putt should be set up on a green with as flat a surface as possible.  
Note: Putting up hill is recommended.
4. Scoring
  - a) The athlete will have five attempts to putt the ball at the hole from a spot 8m from the hole, scoring points according to where the ball comes to rest.

- b) The athlete will score one point for making a stroke at, and striking the ball. (A swing and a miss counts as one attempt, and the athlete receives a score of zero.)
- c) A second point is scored if the ball stops on or within the 1.5m circle.
- d) A third point is scored if the ball stops on or within the 0.5m circle.
- e) If the ball goes in the hole, a total of four points will be awarded for that attempt.
- f) The long putt score shall be the sum total from the five attempts.

### SHORT PUTT

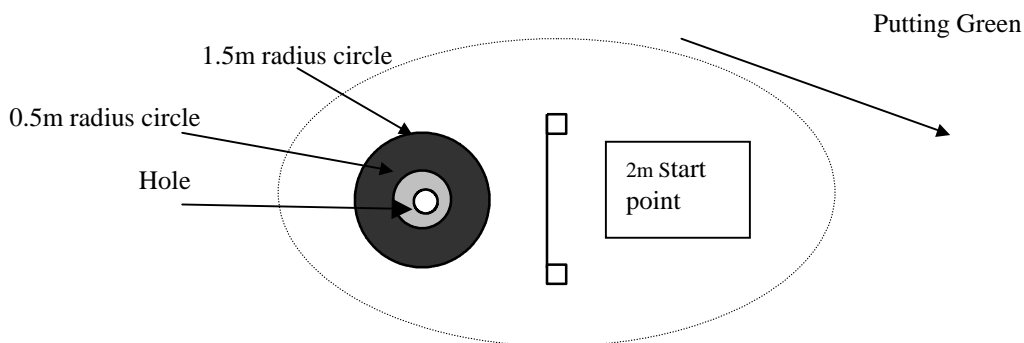

### LONG PUTT

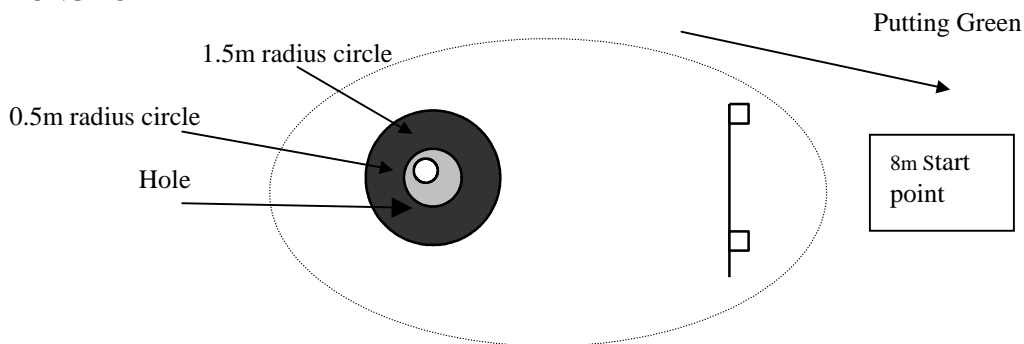

### LEGEND

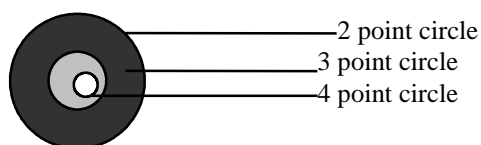

### c. Chip Shot

1. Purpose - To measure the athlete's ability in hitting chip shots 14m from the hole.
2. Equipment
  - a) An assorted number of irons for both right and left handed players.  
Note: Woods and putters are not permitted for this skill.
  - b) Five balls for each hole being used.
  - c) A putting green with a clearly marked target flag and hole.
3. Description
  - a) A chipping area is set up which includes a 3m x 3m square hitting area 14m from the hole. The chipping area should be between 1m and 2m from the edge of the green.
  - b) A 6m radius circle and a 3m radius circle will be placed around the hole.
  - c) A safely marked hitting area 3m x 3m square, chalk and marker.

- d) The athlete is instructed to chip the ball at a designated hole getting it as close to the hole as possible.
- e) **Size of target circle may vary due to facility limitations.**
- f) **Ball must be placed and hit from the grass and not off of a tee.**

4. Scoring

- a) The athlete will attempt five shots at the target, scoring points according to where the ball comes to rest.
- b) Athletes will score one point for making a stroke at and striking the ball. (A swing and a miss counts as one shot and receives a zero score for that shot.)
- c) A second point is scored if the ball comes to rest inside the 6m circle around the hole.
- d) A third point is scored if the chip shot comes to rest inside the 3m circle around the hole.
- e) A fourth point is scored if the ball comes to rest in the hole.
- f) The total score from the five attempts will be the athletes' final score for the chip shot.

**CHIP SHOT**

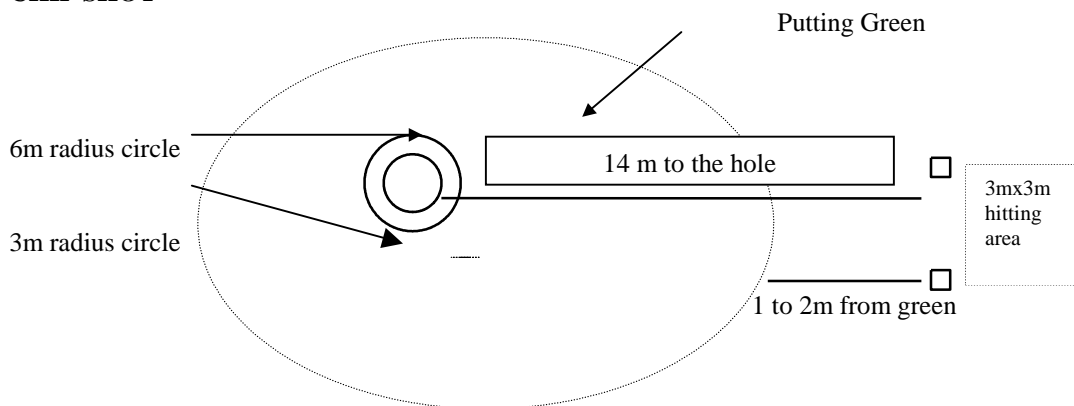

**LEGEND**

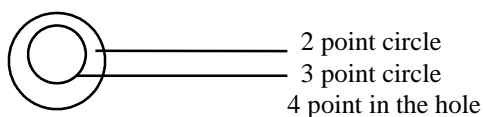

d. The Pitch Shot

1. Purpose - To measure the athlete's ability in hitting controlled pitch shots in the air in the proper direction to a defined circular target area. This skill may also be set-up over a hazard (sand trap or hill).
2. Equipment
  - a) An assorted number of pitching irons for both right and left handed players.
  - b) Five golf balls for each station being used.
  - c) A marked hitting area, paint or chalk, and marker.
  - d) Shag bags or tubes to retrieve balls at station.
  - e) A target flag and hitting mat or artificial surface.
  - f) A banner, sign, net or barrier that measures 1m in height and 5m wide.
3. Description
  - a) A target area shall be defined as a circle with a 12m diameter.
  - b) The distance from the hitting area to the 1m high barrier shall be 5m.
  - c) The distance from the 1m high barrier to the target area shall be 5m.
  - d) The golfer shall make five attempts. The athlete is instructed to pitch the ball over the barrier at the designated target area.

Note: Skill station should be located in restricted area such as range in order to provide safest environment. If an unrestricted area is used than area should be roped off and clearly identified for volunteers, spectators, and athletes.

  - e) **Size of target circle may vary due to facility limitations.**
  - f) **Ball must be placed and hit from the grass and not off of a tee.**

#### 4. Scoring

- a) The athlete will attempt five shots at the target, scoring points according to where the ball lands.
- b) Athletes will score one point for making a stroke at and striking the ball. (A swing and a miss counts as one shot and receives a zero score for that shot.)
- c) A second point is scored if the ball goes over the barrier and between the upright poles.
- d) A third point is scored if the ball lands inside the 12m circle and rolls out or if the ball lands outside the 12m circle and comes to rest inside the circle.
- e) A fourth point is scored if the ball lands inside the 12m circle and comes to rest inside the circle.
- f) The pitch shot score shall be the sum total from the five attempts.

## PITCH SHOT

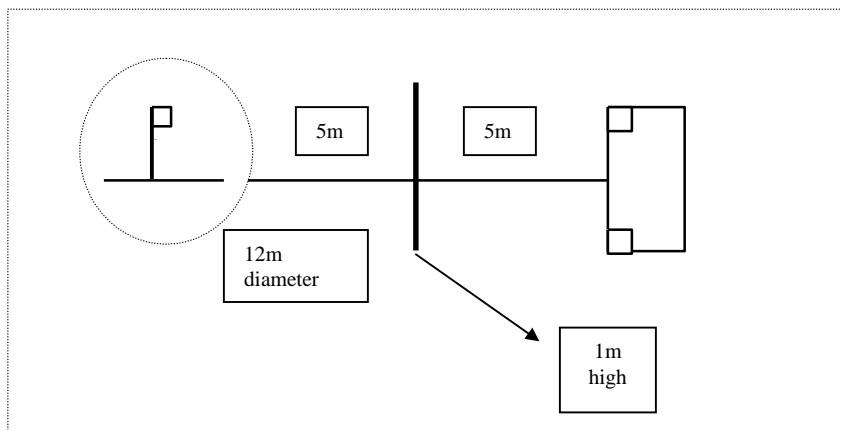

#### e. Iron Shot

1. Purpose - To measure the athlete's ability to hit an iron shot for distance within a set hitting area.
2. Equipment
  - a) An assorted number of irons for right and left handed players.
  - b) An appropriate number of golf balls based on the number of competitors. It is recommended that five balls per athlete be available to eliminate having to retrieve balls.
  - c) Marking paint or chalk and marker to mark hitting area and boundary lines. (1/2" cord or rope can be substituted for marking boundary lines and making them more visible.)
  - d) Hitting mat or carpet, tees, helmets, a safety zone for scorekeepers to stand in and shag bags or tubes to retrieve balls (if necessary).
  - e) A target flag and eight cones or other visible marker to identify distance locations.
3. Description - The athlete may choose to hit the ball off a tee, a mat or the ground. The athlete is instructed to hit the ball from the teeing area toward a designated flag in the hitting area trying to keep the ball within the boundary markers and achieving a distance of more than 90m yards.
4. Scoring
  - a) The athlete will attempt five shots at the target, scoring points according to where the ball comes to rest.
  - b) Athletes will score one point for making a stroke at and striking the ball. (A swing and a miss count as one attempt and the athlete receives a score of zero for that shot.)
  - c) Two points are scored for a ball that comes to rest between the 30m and 60m yd lines within the 35m wide boundary lines.
  - d) Three points are scored for a ball that comes to rest between the 60m and 90m lines within the 35m wide boundary lines.
  - e) Four points are scored for a ball that comes to rest beyond the 90m line within the 35m wide boundary lines.
  - f) The athlete's score for the iron shot shall be the sum total of the five attempts.

**g) Size of boundaries may vary due to facility limitations.**

## IRON SHOT

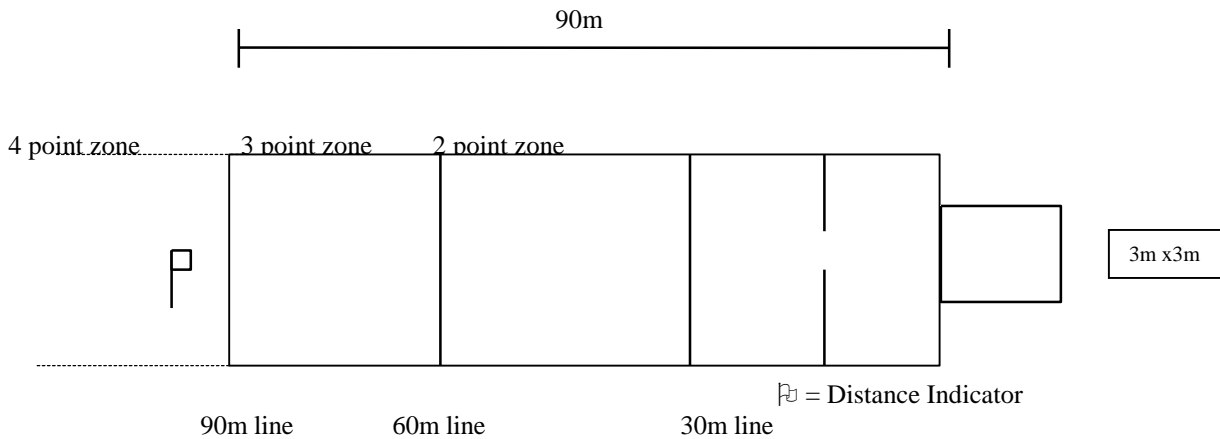

### f. Wood Shot

1. Purpose - To measure the athlete's ability to hit a wood shot for distance within a set hitting area.
2. Equipment
  - a) An assorted number of woods for right and left handed players.
  - b) An appropriate number of golf balls based on the number of competitors. It is recommended that five balls per player be available to eliminate having to retrieve balls.
  - c) Marking paint or chalk and marker to mark hitting area and boundary lines. (A 1/2" cord or rope can be substituted for marking boundary lines and making them more visible.)
  - d) Hitting mat or carpet, tees, helmets, a safety zone for scorekeepers to stand in and shag bags or tubes to retrieve balls (if necessary).
3. Description
 

The athlete may choose to hit the ball off a tee, a mat or the ground. The athlete is instructed to hit the ball from the teeing area toward a designated flag in the hitting area trying to keep the ball within the boundary markers and achieving a distance of more than 90m.
4. Scoring
  - a) The athlete will attempt five shots at the target, scoring points according to where the ball comes to rest.
  - b) Athletes will score one point for making a stroke at and striking the ball (a swing and a miss counts as one attempt and the athlete receives a score of zero for that shot.)
  - c) Two points are scored for a ball that comes to rest between the 60m and 90m lines with the 50m wide boundary lines.
  - d) Three points are scored for a ball that comes to rest between the 90m and 120m lines within the 50m wide boundary lines.
  - e) Four points are scored for a ball that comes to rest beyond the 120m line within the 50m wide boundary lines.
  - f) The athlete's score for the iron shot shall be the sum total of the five attempts.
  - g) **Size of boundaries may vary due to facility limitations.**

## WOOD SHOT

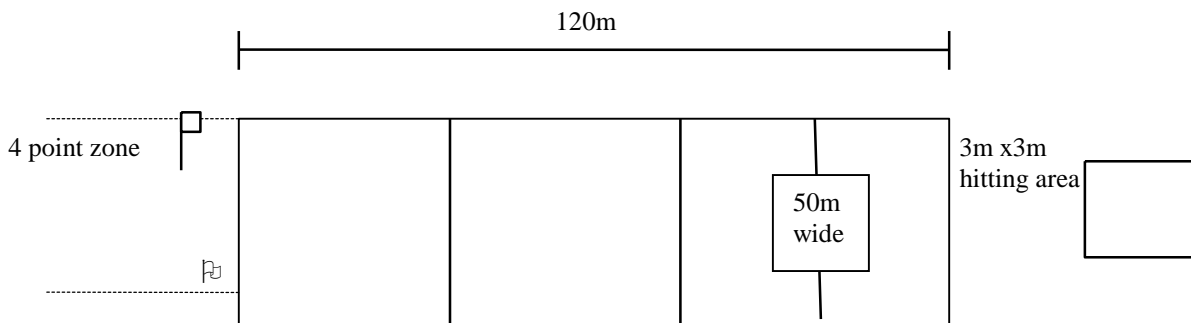

120m line

90m line

60m line

## **Scorecards:**

To provide equitable heats for the skills competition, the committee needs a reasonable idea of how an athlete may perform so each athlete must submit scores from a supervised skills test. An athlete can perform all the skills at one time or the skills can be spread over several practices. If by some chance you are unable to complete a full set of scores for a given athlete, please enter your best guess for untested skills based on your knowledge of the athlete. The most important number is the total.

# SPECIAL OLYMPICS

## NORTHERN CALIFORNIA & NEVADA

### INDIVIDUAL SKILLS GOLFER'S SCORECARD

Golfer's Name: \_\_\_\_\_ Division: \_\_\_\_\_

Delegation: \_\_\_\_\_ Coach's Name: \_\_\_\_\_

Coach's Phone #: \_\_\_\_\_

<b>SKILLS</b>	<b>Attempt 1</b>	<b>Attempt 2</b>	<b>Attempt 3</b>	<b>Attempt 4</b>	<b>Attempt 5</b>	<b>TOTAL</b>
<b>Short Putt</b>	/4	/4	/4	/4	/4	/20
<b>Long Putt</b>	/4	/4	/4	/4	/4	/20
<b>Chip Shot</b>	/4	/4	/4	/4	/4	/20
<b>Pitch Shot</b>	/4	/4	/4	/4	/4	/20
<b>Iron Shot</b>	/4	/4	/4	/4	/4	/20
<b>Wood Shot</b>	/4	/4	/4	/4	/4	/20
					<b>TOTAL</b>	<b>/120</b>

**Golfer will have 5 attempts for each skill.**

**SHORT PUTT:**

Scoring: 0 points if swing and a miss; 1 point if ball is hit; a second point if ball stops in the 1.5m circle; a third point if ball stops in 0.5m circle, four points if ball goes in hole. (Maximum of 20 points)

**LONG PUTT:**

Scoring: 0 points if swing and a miss; 1 point if ball is hit; a second point if ball stops in the 1.5m circle; a third point if ball stops in 0.5m circle; four points if ball goes in hole. (Maximum of 20 points)

**CHIP SHOT:**

Scoring: 0 points if swing and a miss; 1 point if ball is hit; a second point if ball stops inside 6m circle; a third point if ball lands on green & stops in 3m circle; four points if ball goes in hole.

**PITCH SHOT:**

Scoring: 0 points if swing and a miss; 1 point if ball is hit; a second point if ball goes over net & between poles; a third point if ball lands in circle & rolls out; four points if ball lands & stays inside 12m diameter circle.

**IRON SHOT:**

Scoring: 0 points if swing and a miss; 1 point if ball is hit; a second point if ball stops over 30m line & stays in bounds; a third point if ball stops over 60m line and stays in bounds; a fourth point if ball stops over 90m line.

**WOOD SHOT:**

Scoring: 0 points if swing and a miss; 1 point if ball is hit; a second point if ball stops over 60m line & stays in bounds; a third point if ball stops over 90m line and stays in bounds; a fourth point if ball stops over 120m line.

